



# BMS Mini 2.1

Centralized battery management system

CONNECTION MANUAL

Revision 2 (21-December-2023)

# Contents

1	Device description .....	3
1.1	Main functions .....	3
1.2	Specifications.....	5
1.3	Typical battery system.....	6
1.4	Safety rules.....	6
2	Device connection .....	7
2.1	Headers .....	7
2.1.1	X1 – header for contactors.....	7
2.1.2	X2 – mini-USB connector. ....	8
2.1.3	X3 – header for discrete inputs and outputs signals.....	8
2.1.4	X4 – header for CAN and RS485 interfaces.....	9
2.1.5	X5 – header for ON/OFF button.....	10
2.1.6	X6 – header for cells temperature sensors.....	10
2.1.7	X7 - header for current sensor. ....	10
2.1.8	X8 – header for battery cells.....	11
2.1.9	X9 – header to power the device.....	12
2.1.10	J1 – jumper for switching CAN bus terminal resistor.....	12
2.1.11	J2 – jumper for switching RS-485 terminal resistor .....	12
2.2	Connection procedure .....	13
2.2.1	Connecting battery cells .....	13
2.2.2	Connecting thermistors .....	13
2.3	Installation procedure.....	14
3	Contacts.....	16
4	Revision history .....	17
5	Notes .....	18

# 1 Device description

The BMS Mini is a centralized battery management system (BMS) that provides monitoring, balancing, and protection of a lithium-ion battery. It measures voltage of each cell and the entire battery, monitors battery temperature and current. It protects the battery from overcurrent, overcharge, deep discharge, and overheating.

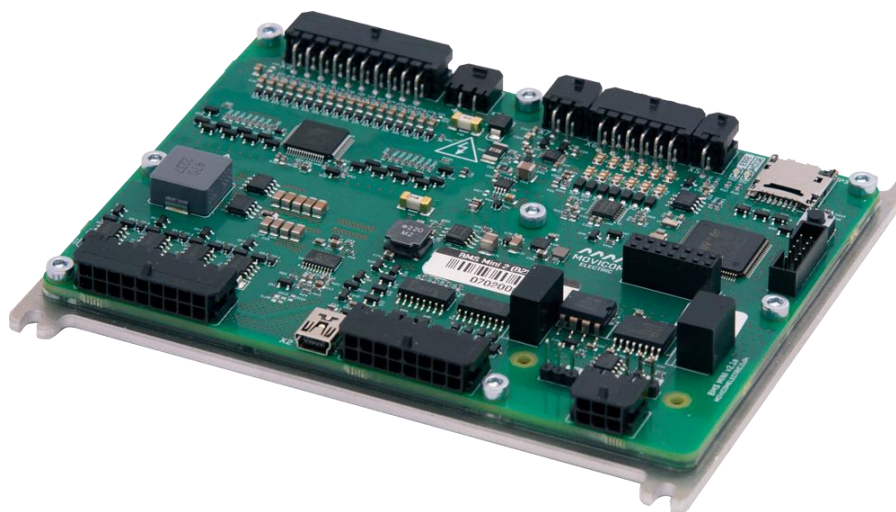

Figure 1. BMS Mini 2.1

The BMS Mini supports **24-, 36- and 48 volts** batteries and measures currents of up to **1200 amps**.

## 1.1 Main functions

- Chemistry – LFP (LiFePO<sub>4</sub> and LiFeYPO<sub>4</sub>), LCO (LiCoO<sub>2</sub>), LMO (LiMn<sub>2</sub>O<sub>4</sub>), NMC (LiNiMnCoO<sub>2</sub>), NCA (LiNiCoAlO<sub>2</sub>), etc.
- Number of cells in series – from 6 to 18
- Voltage, volts – up to 80
- Capacity – from ones to thousands A×h
- Fully configurable for different types of batteries (voltage levels, capacity, protections levels and delays)
- Determination of battery status:
  - State of charge (SOC)
  - Depth of discharge (DOD)
  - State of health (SOH)
  - Effective capacity
  - Cell resistance
  - Cycles counter

- Energy counters (received, consumed, and dissipated by balancing resistors)
- Cell monitoring:
  - Measuring voltages of every cell
  - Measuring temperature of cells
- Current monitoring (bidirectional Hall-Effect sensor with supply voltage 5 volts)
- Battery protections:
  - Overcurrent
  - Undervoltage
  - Overvoltage
  - High temperature
  - Low temperature
  - Heater control
  - Cooler control
  - etc.
- Cell balancing (passive balancing at 220 mA @4.2V)
- Continuous logging on an SD card (full battery and BMS state)
- Interfaces:
  - CAN (CANopen protocol to configure the BMS, interaction with external equipment)
  - RS-485 (Modbus RTU)
  - USB (to configure the BMS)
  - Wi-Fi or GSM (optional)

## 1.2 Specifications

Parameter	Value
Cell chemistry	LCO, LFP, LMO, NMC, NCA, etc.
Battery voltage, V	14÷78
Number of cells	6÷18
Number of temperature sensors	1÷6
Type of temperature sensors	100kOhm NTC thermistor
Number of MOSFETs <sup>1)</sup>	4
Number of discrete inputs	4
Number of discrete outputs	4
Current sensor type	Hall-Effect sensor, bidirectional, supply voltage 5 V (LEM series HASS, HTFS, DHAB)
Number of CAN transceivers	1
CAN bus speed, kbps	125, 250 (by default), 500, 1000
Number of RS-485 transceivers	1
RS-485 baud rate, bps	600, 1200, 2400, 4800, 9600 (by default), 19200, 38400, 57600, 115200
USB 2.0 speed, Mbps	12
Current consumption @48 V, mA, max: <ul style="list-style-type: none"> <li>▪ work (no load)</li> <li>▪ standby</li> </ul>	30 0.2
<b>Operating conditions</b>	
<b>Operating temperature range, °C</b>	<b>-40÷85</b>

<sup>1)</sup> – The MOSFETs switch the charging, precharging, and discharging contactors.

### 1.3 Typical battery system

There is a typical battery system based on the BMS Mini in Figure 2.

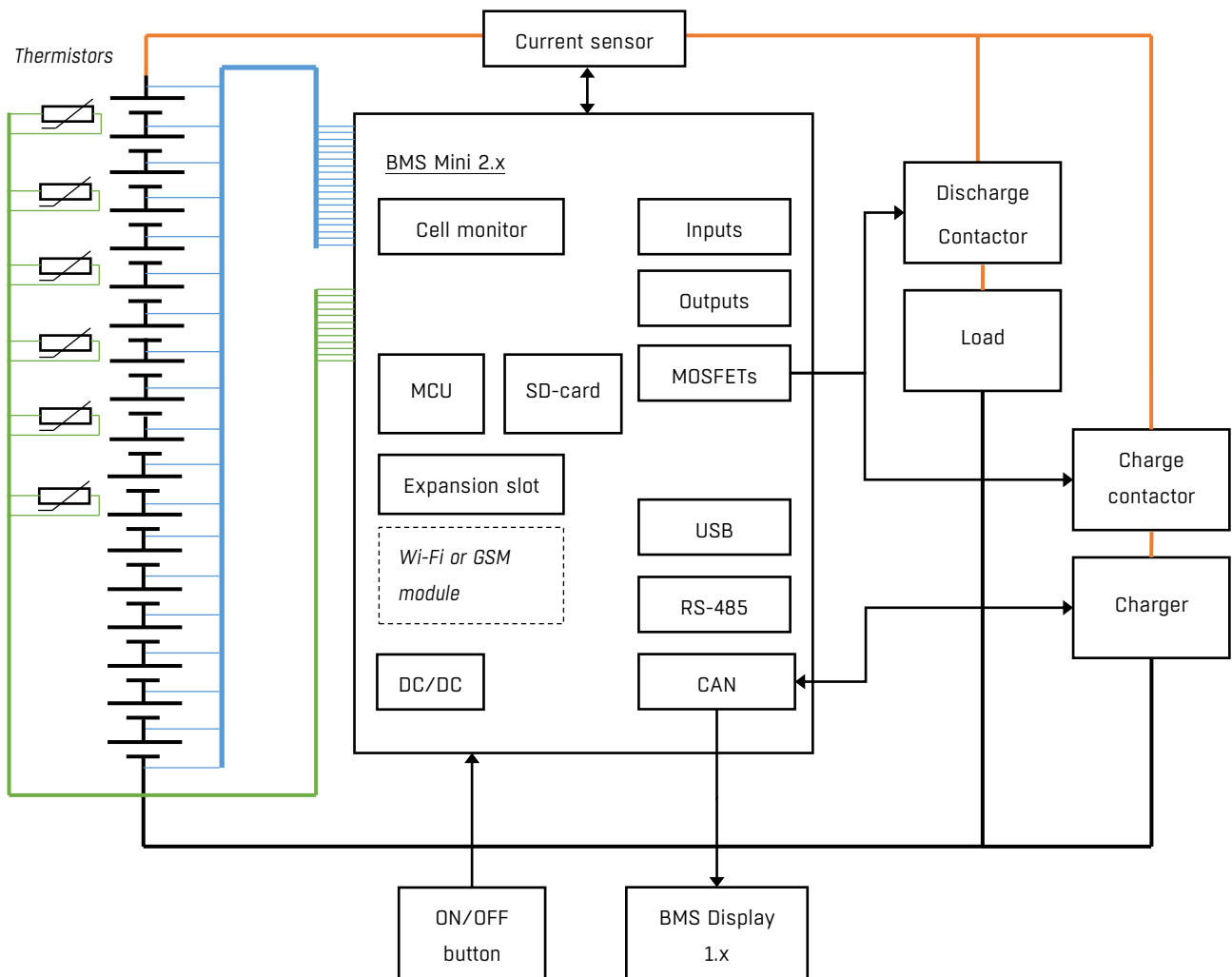

Figure 2. Block diagram of a typical battery system

### 1.4 Safety rules

The BMS can be connected to batteries with life-threatening and health-hazardous voltage levels. When working with high-voltage batteries, observe electrical safety regulations, use safety glasses, protective clothing, insulated tools, and appliances.

The system is not designed to work with batteries, the total voltage of which is more than 80 volts.

## 2 Device connection

### 2.1 Headers

There are names and locations of the BMS Mini headers in Figure 3.

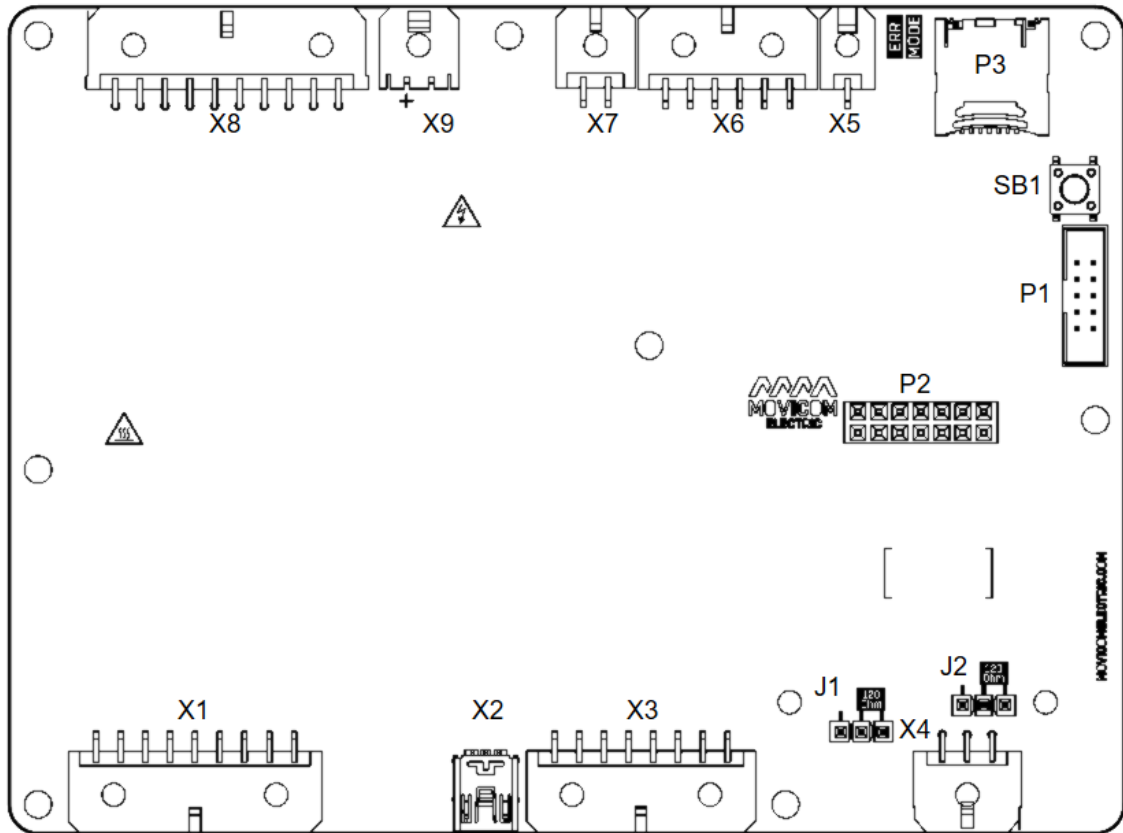
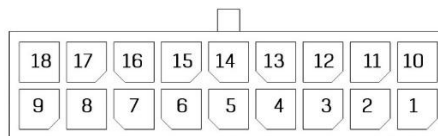

Figure 3. The BMS Mini headers

#### 2.1.1 X1 – header for contactors.



Pin	Name	Description
1	-	-
2	+12V	Supply voltage from the internal 12V DC/DC converter
3	GND	Ground
4	+12V	Supply voltage from the internal 12V DC/DC converter
5	GND	Ground
6	+12V	Supply voltage from the internal 12V DC/DC converter

7	GND	Ground
8	+12V	Supply voltage from the internal 12V DC/DC converter
9	GND	Ground
10	-	-
11	FB1	Feedback signal from contactor 1
12	OUT1	Contactor control 1 (low side switch), 100V, max 5A
13	FB2	Feedback signal from contactor 2
14	OUT2	Contactor control 2 (low side switch), 100V, max 5A
15	FB3	Feedback signal from contactor 3
16	OUT3	Contactor control 3 (low side switch), 100V, max 5A
17	FB4	Feedback signal from contactor 4
18	OUT4	Contactor control 4 (low side switch), 100V, max 5A

**ATTENTION!!!**

The load should be connected to +12V and OUTx pins. The feedback signal should be connected to FBx and GND pins. Below is an example of connecting the BMS to a contactor:

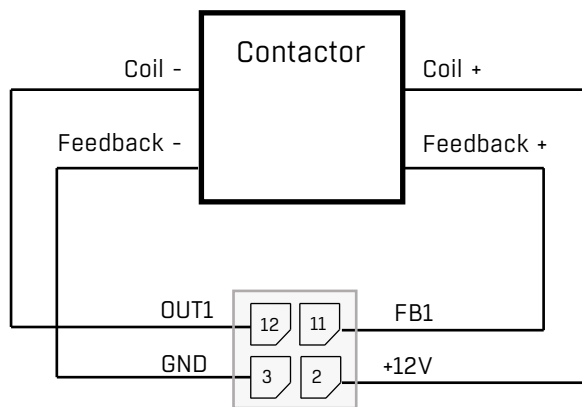

2.1.2 X2 – mini-USB connector.

2.1.3 X3 – header for discrete inputs and outputs signals.

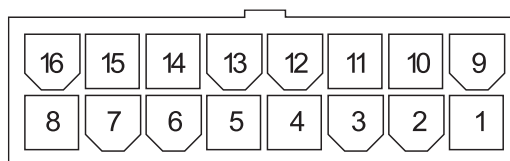

Pin	Name	Description
1	DIN1	Discrete input 1 “dry contact” (+5V)



2	DIN2	Discrete input 2 “dry contact” (+5V)
3	DIN3	Discrete input 3 “dry contact” (+5V)
4	DIN4	Discrete input 4 “dry contact” (+5V)
5	DOUT1	Discrete output 1 (+5V, 20mA)
6	DOUT2	Discrete output 2 (+5V, 20mA)
7	DOUT3	Discrete output 3 (+5V, 20mA)
8	DOUT4	Discrete output 4 (+5V, 20mA)
9	GND	Discrete input 1 “dry contact” (ground)
10	GND	Discrete input 2 “dry contact” (ground)
11	GND	Discrete input 3 “dry contact” (ground)
12	GND	Discrete input 4 “dry contact” (ground)
13	GND	Discrete output 1 (ground)
14	GND	Discrete output 2 (ground)
15	GND	Discrete output 3 (ground)
16	GND	Discrete output 4 (ground)

2.1.4 X4 – header for CAN and RS485 interfaces.

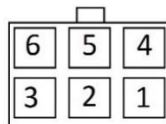

Pin	Name	Description
1	RS485_B	RS485 line B
2	+5V	Isolated supply voltage 5V, max 400mA
3	CAN_L	CAN-L line of the CAN bus
4	RS485_A	RS485 line A
5	GND	Isolated ground
6	CAN_H	CAN-H line of the CAN bus

2.1.5 X5 – header for ON/OFF button.

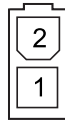

Pin	Name	Description
1	<b>BTN</b>	Signal to turn on/off the BMS (“dry contact”, +3.3V)
2	<b>GND</b>	Signal to turn on/off the BMS (“dry contact”, ground)

2.1.6 X6 – header for cells temperature sensors.

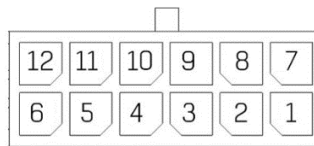

Pin	Name	Description
1	<b>TEMPG1</b>	Ground of the thermistor 1
2	<b>TEMPG2</b>	Ground of the thermistor 2
3	<b>TEMPG3</b>	Ground of the thermistor 3
4	<b>TEMPG4</b>	Ground of the thermistor 4
5	<b>TEMPG5</b>	Ground of the thermistor 5
6	<b>TEMPG6</b>	Ground of the thermistor 6
7	<b>TEMP1</b>	Signal from the thermistor 1
8	<b>TEMP2</b>	Signal from the thermistor 2
9	<b>TEMP3</b>	Signal from the thermistor 3
10	<b>TEMP4</b>	Signal from the thermistor 4
11	<b>TEMP5</b>	Signal from the thermistor 5
12	<b>TEMP6</b>	Signal from the thermistor 6

2.1.7 X7 - header for current sensor.

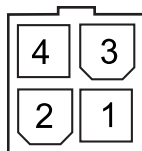

Pin	Name	Description
1	+5V	Supply voltage for a current sensor 5V, max 50 mA
2	GND	Ground
3	Vcs	ADC input (current sensor output)
4	Vref	Auxiliary ADC input (current sensor reference signal)

### 2.1.8 X8 – header for battery cells

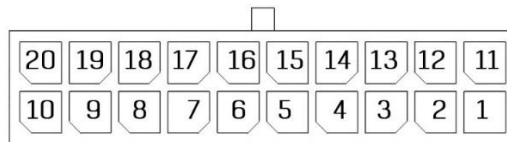

Pin	Name	Description
1	C0	Minus of the cell stack (for measuring purposes only)
2	C2	Cell 2
3	C4	Cell 4
4	C6	Cell 6
5	C8	Cell 8
6	C10	Cell 10
7	C12	Cell 12
8	C14	Cell 14
9	C16	Cell 16
10	C18	Cell 18 (maximum potential of the cell stack, for measuring purposes only)
11	NC	Not connected
12	C1	Cell 1 (minimum potential with respect to C0)
13	C3	Cell 3
14	C5	Cell 5
15	C7	Cell 7
16	C9	Cell 9
17	C11	Cell 11
18	C13	Cell 13

19	C15	Cell 15
20	C17	Cell 17

2.1.9 X9 – header to power the device

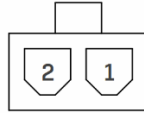

Pin	Name	Description
1	VBAT+	Supply voltage for BMS Mini
2	VBAT-	BMS Mini power ground

Attention! The BMS Mini S device is galvanically connected to the battery (the minus of the battery is the device ground). In view of this, when a BMS Wi-Fi or BMS GSM module is connected to the device, the antenna braid will also be galvanically connected to the battery (connected to the battery negative). It is recommended to isolate the antenna cable from the battery case to prevent negative potential from appearing on the case.

2.1.10 J1 – jumper for switching CAN bus terminal resistor

To connect the terminal resistor between the **CAN\_H** and **CAN\_L** lines, install the jumper J1 according to the following figure:

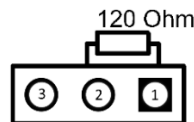

2.1.11 J2 – jumper for switching RS-485 terminal resistor

To connect the terminal resistor between the **RS485\_A** and **RS485\_B** lines, install the jumper J1 according to the following figure:

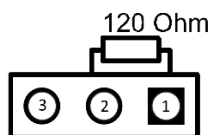

## 2.2 Connection procedure

### 2.2.1 Connecting battery cells

To connect battery cells, follow Figure 4. Incorrect connection of the cells can damage the BMS Mini.

Begin the connection with the negative line of the battery: the “C0” is connected to the “B-”, then the first cell (C1) is connected, then the second (C2), etc. If not all inputs of the cells are used, then the remaining inputs are connected to the cell with the most potential.

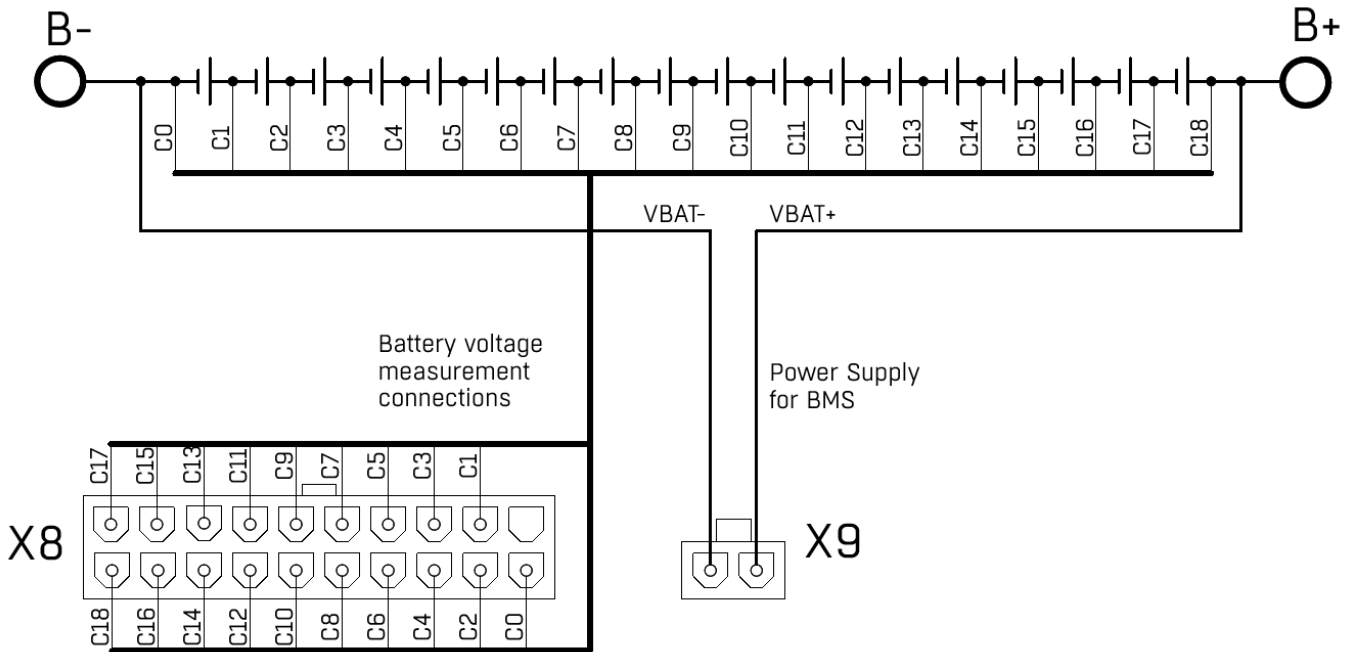

Figure 4. Connecting battery to headers X8 and X9

### Attention!

Connect the battery according to the diagram, otherwise the device may be damaged.

### 2.2.2 Connecting thermistors

Thermistors should be fastened to the cells, excluding short circuits to the cell terminals (for example, isolate thermistors with heat shrink).

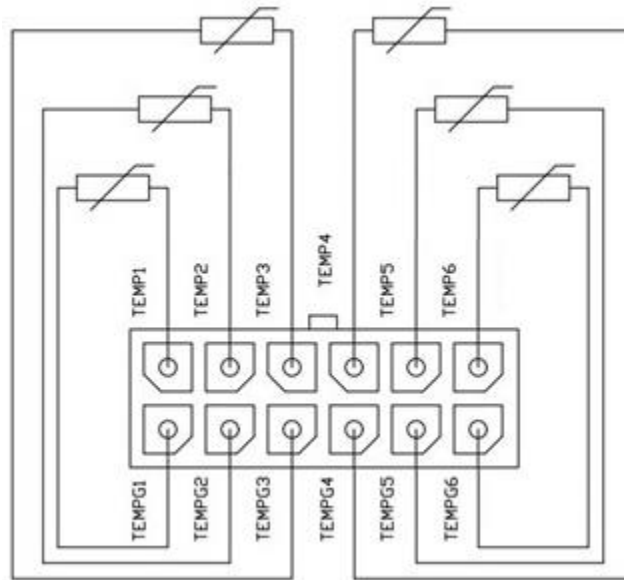

Figure 5. Connecting thermistors to header X6

## 2.3 Installation procedure

The mounting area of the BMS Mini must be protected from mechanical particles (dust, dirt, large objects) and water. The BMS Mini is recommended to be placed close to the cells it controls, but away from high current circuits to reduce interference to measuring circuits and increase overall reliability of installation.

The installation site must provide convenient access for subsequent connection to the device's headers for connecting other system elements: a current sensor, contactors, display panels.

The BMS Mini has a heat sink to dissipate the heat generated during the balancing of the cells. When used in enclosed enclosures, heat must be removed from the sink, otherwise it may damage the device.

Overall and mounting dimensions of the BMS Mini are shown in Figures 6 and 7.

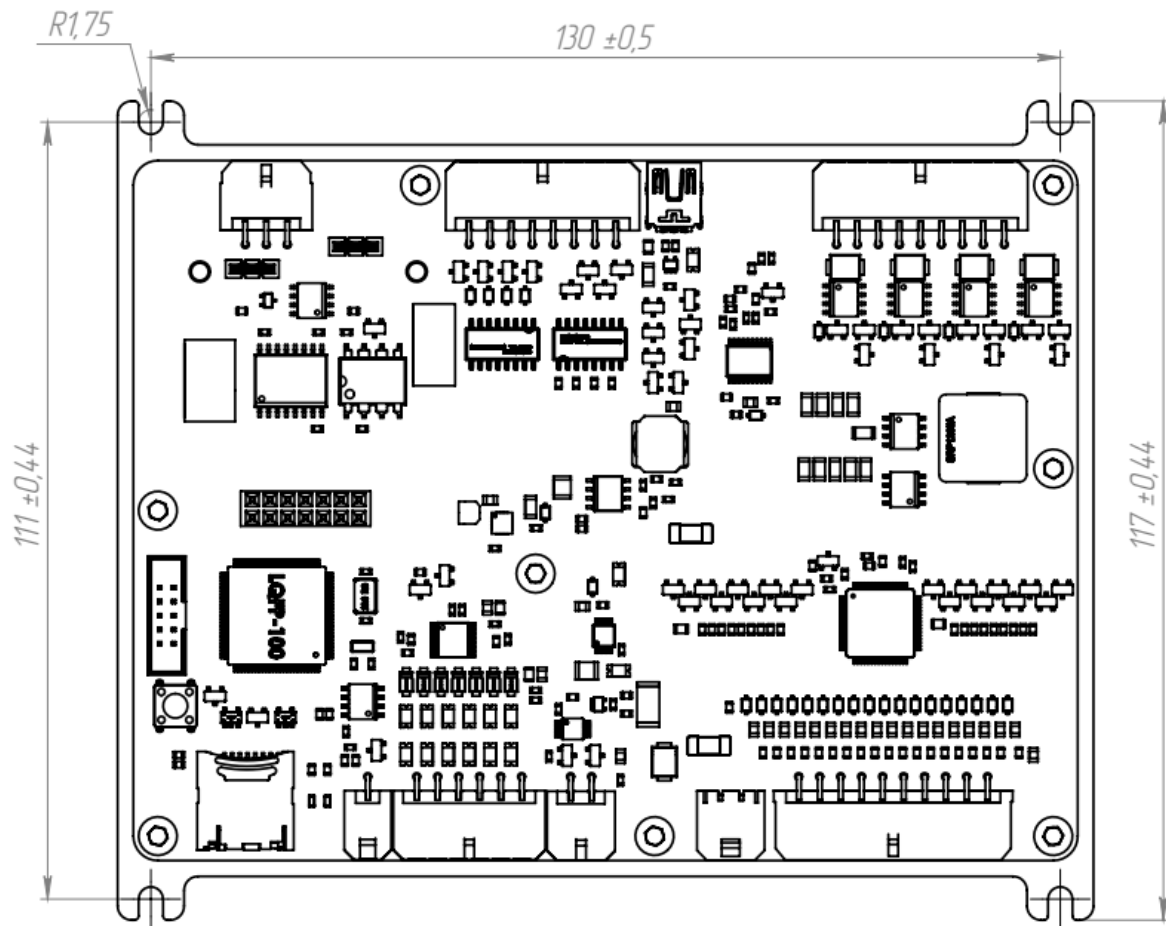

Figure 6. Dimensions of the BMS Mini (top view)

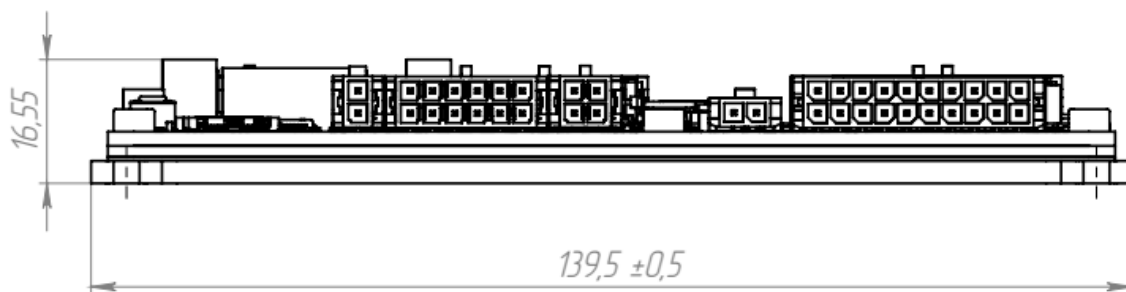

Figure 7. Dimensions of the BMS Mini (side view)

Parameter	Value
Overall dimensions (length × width × height), mm	139.5 × 117 × 17
Mounting dimensions (length × width), mm	130 × 111
Mounting holes	M3

### 3 Contacts

*Movicom Electric*



7190 Sunset Blvd # 200, Los Angeles, CA, USA



+1 323 633 7033



[electric@movicom.com](mailto:electric@movicom.com)

[movicomelectric.com](http://movicomelectric.com)



## 4 Revision history

Rev. number	Rev. date	Changes
1	18-April-2023	First revision
2	21-December-2023	Updated the section describing X9 connector that is used to power the device

# 5 Notes

---

---

---

---

---

---

---

---

---

---

---

---

---

---

---

---

---

---

---

---

---

---

---

---

---

---